

▶ System profili :	
Numery profili	

▶ Sposób stabilizowania listew

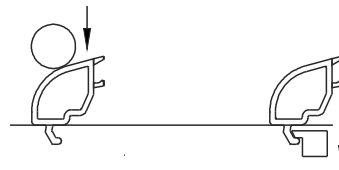

▶ Sposób cięcia listew

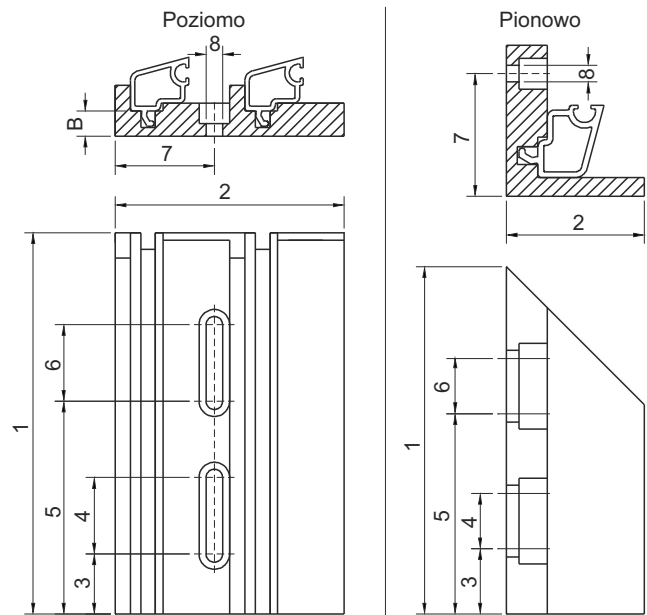

▶ Piła do listew przyszybowych	
producent:	
typ:	
rok produkcji:	
numer seryjny:	

▶ Rodzaj mocowania	
Śruby	
Kołki	
Wsuwane	
Inne	
Brak	

▶ Wymiary [mm]

B	3	6
1	4	7
2	5	8

Dodatkowe informacje:

		DATA/PODPIS
--	--	-------------